

ANALYSIS OF MICRO-PROFILE MACHINING OF THE NON-PLANAR SURFACES OF INJECTION MOLDS FOR POLYMERIC COMPOSITES

DANIEL ȘERBAN¹, CONSTANTIN GHEORGHE OPRAN²

Abstract: Plastics are one of the 21st Century materials with an innovative development to meet the society's targets: resource efficiency, zero-energy buildings, saving water, reducing the gas emissions, waste as a resource, recycling closing the loop of "Circular Economy", to name only few. Injection molding of polymeric composites products is one of the most used processes with low cost, good accuracy and high productivity. Mold surfaces are influencing the product quality, the ejection, the flow, and the aesthetic of the part. In this paper we analyze the micro profiling of the non-planar surfaces of an injection mold for a scaled model of a 15th Century stone church from Hațeg County, Romania. We present a study of milling the micro-profiles (details of bricks and stone in the range of 100 to 500 μm) directly into the mold cavities and milling the electrodes followed by electrical discharge machining. For the milling process two strategies were compared: milling the 3-dimension model and milling/engraving the vector pattern projected on the non-planar surfaces. The experiments consisted in building an aluminum mold and evidenced a good replication by injection molding the model parts in a composite of recycled polystyrene matrix, results being compared with the flow simulation.

Key words: Injection molding; micro-profile; polymeric composites;

1. INTRODUCTION

This paper presents two methods for micro-profiling the injection mold surfaces of a scaled model of 15th century stone church. Estimating details in 3 dimensions for architecture from imagery presented interest to researchers and were proposed methods and software for obtaining surfaces patterns. Modeling in 3 dimensions is not only a creative activity but also a cognitive one as digital models

¹ *Eng. Ph.D., University Politehnica of Bucharest, dserban@ddplast.ro*

² *Prof., Eng. Ph.D., University Politehnica of Bucharest*

which allow simulation, visualization. Modeling in 3 dimensions helps the manufacture of complex polymer composites injection moulds and to analyze the flow simulation. Micro-profile finishing the surfaces requires a lot of labor for available technologies: chemical etching, laser ablation, milling or electrical discharge machining. With the goal to find low-cost solutions, in our study we compare a method of combining 2D vector extraction from image of a brick and to 3D pattern onto mold surface with machining by generating the tool path on the surface projected vectors.

2. RELATED WORKS

There are studies regarding the reconstruction of historical buildings and suggested methods for 3D digital modeling (Spallone, 2007), parsing architecture within plan drawings (Willis, 2009), who suggests a methodology in 7 steps: digitize the manuscript, pre-process the image, estimate a skeleton shape, vectorize, estimate a shape, each pixel in the binary image is assigned a semantic label and construct the 3D model; estimating details of Gothic architecture from imagery versus other methods which integrate the 3D measurements with texture data (Willis, 2010), or five-axis tool path generation for 3D curves created by projection on B-spline surfaces (Can and Unuvar, 2010), 3D reconstruction models for 3D engraving from 2D images by hybrid reverse engineering consisting in transforming an image to gray-scale and reducing the noise followed by cloud points extraction techniques for interactive design of brickworks by integrating two computational platforms – based on image and on parametric modeling (Afsari et al, 2014).

3. EXPERIMENTS

We choosed as model a 15th Century stone church from Hațeg County, Romania. This paper analyses the micro machining path generation of the 3D surfaces of an aluminum EN 7075 injection mould for a church scaled model, details of bricks and stone. One method consists in extracting vectors from a picture and project the 2D sketch onto the 3D surface and second method consists in 3D modeling the solid and milling with a pocket strategy followed by a parallel finishing.

For vector extraction was used an image of the North Wall apse and a raster resolution of 96 DPI (dots per inch), on a Stentiford Algorithm (Kumar and Teja, 2014). The vector extraction was exported in dxf format (Drawing Interchange Format) and then imported as a 2D sketch into the CAD/CAM software as presented in Fig.1 (b). The sketch was used to micro profile the electrode for the North mould cavity as a projection on the 3D surface tool paths. Then we investigated the milling and electrical discharge technologies of micro profiling the 3D surfaces and the replication by injection molding of a polymeric composite made of a high impact polystyrene matrix with ceramic powder 5%.

Table 1. List of operations and time consumed for completion the micro profiling of mould surfaces

Operation	Method A [Hours] North Wall	Method B [Hours] South Wall
Design CAD (3D modeling) the walls	1	1
Modeling The Mould Cavities	1	1
Extract vectors from picture, 2D sketch	1/2	-
Modeling 3D detail of wall texture	-	2
Milling the cavities (no texture)	3	3
Modeling and milling the electrode for North Wall	2	-
Micro Milling the electrode	1	-
Electrical Discharge Machining	1/2	-
Micro Milling The South Wall Surface	-	1
Total [hours]	9	8

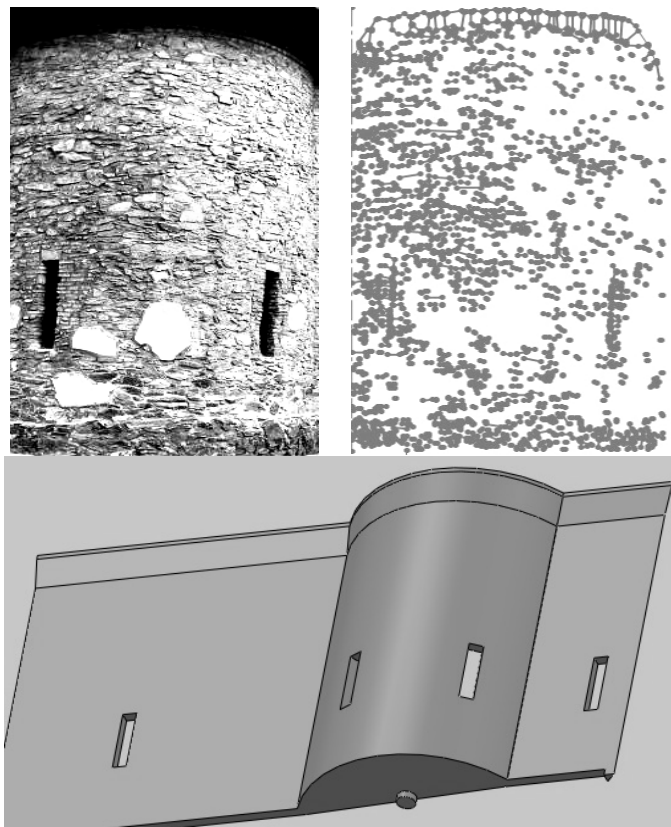

Fig. 1. (a) Church North Wall (Apse detail) ; (b) Vectors extraction; (c) 3D Model of Church replica 1:200 scale;

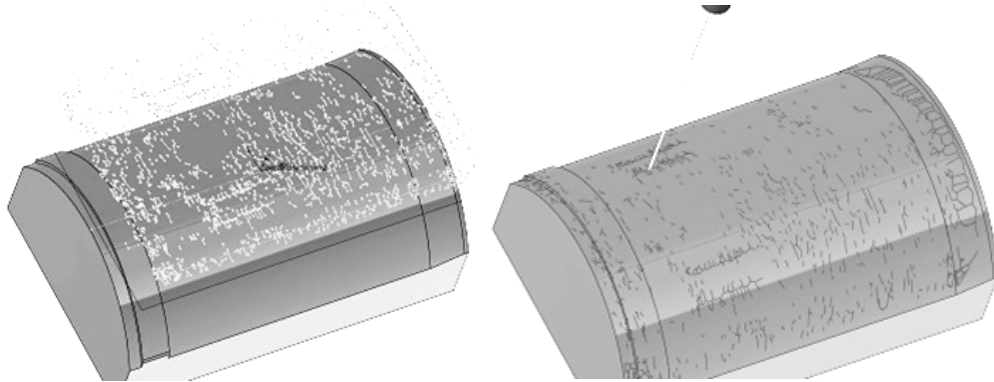

Fig. 2. (a) 2D sketch from picture extracted vectors ; **(b)** 3D Electrode with projected tool path on surface

Micro milling of the copper electrode and of the aluminum cavity was worked with a 0.1 mm pin point carbide tool on a milling machine with direct measurement system and a spindle of maximum 24.000 rpm. We used a projection a 2D sketch on a 3D surface strategy for micro profiling the electrode and a parallel technology for direct carving the South Wall apse cavity.

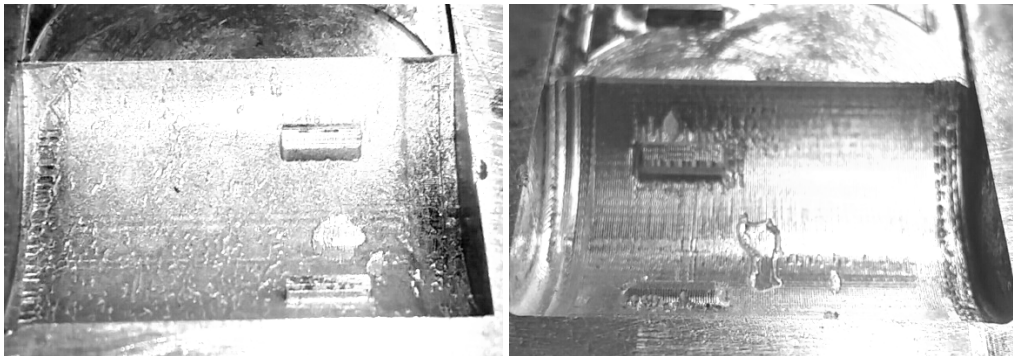

Fig. 3. (a) Electrical Discharge Machining North Wall Cavity; **(b)** Micro Profile Milling South Wall cavity;

Injection molding was performed on 1.000 KN clamping force machine with a 40 mm screw diameter. The pressure into the cavity was measured with a DME analog controller and a pressure sensor model 405C. For a good filling we adopted a strategy in two steps: finding out the injection pressure and the stroke to fill 95% the cavities and only second to pack to 100% the parts. On Table 2 we present a comparison between the flow simulation and measured ones of injection pressure and injection time.

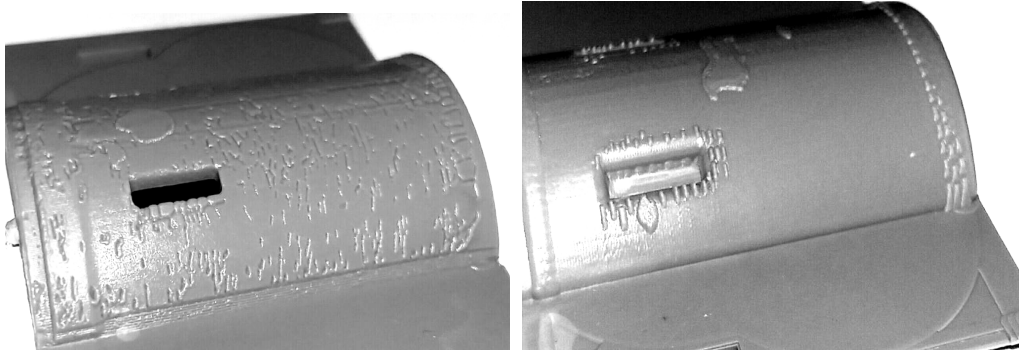

Fig. 4. (a) Detail of North Wall Apse Injection Moulding ; **(b)** Detail of South Wall Apse;

Table 2. Injection Moulding Parameters Comparison

Parameter	Measured Value	Flow Simulation Value
<i>Maximum Cavity Injection Pressure</i>	12.5 MPa	11.7 Mpa
<i>Filling Injection Time</i>	1.1 s	1.3 s

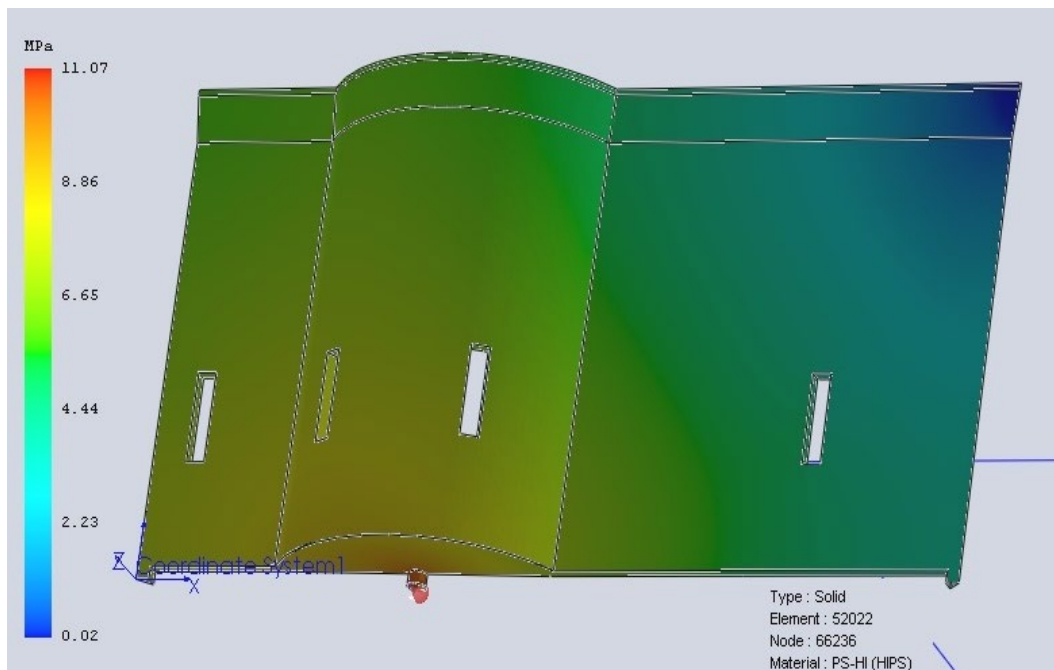

Fig. 4. Flow simulation of North Wall, Maximum Injection Pressure 11.07 MPa;

4. CONCLUSIONS

Vector extraction from image could offer the advantage of a reliable solution saving modeling time for replication of real models into products. It is a good method

to obtain patterns for texturing, micro profiling injection moulds surfaces for polymeric composites. The experiments evidenced a good replication of the surface of the polymeric composite for both methods in machining the micro profiled cavities. 3D modeling helps designing complex assemblies, helps visualization and simulation.

REFERENCES

- [1]. **Afsari, K., Gentry, R., Swarts, M.E.,** *Integrated Generative Technique for Interactive Design of Brickworks*, Conference Paper, Itcon Vol. 19, pg. 225-247, (2014)
- [2]. **Can, A., Unuvar, A.,** *Five-axis tool path generation for 3D curves created by projection on B-spline surfaces*, Int J Adv Manuf Technol (2010) 49:1047-1057, DOI:10.1007/s00170-009-2459-z, (2009)
- [3]. **Kumar, A., Teja, V., R.,** *Edge Detection Based on Otsu Method and Stentiford Algorithm*, IJERT, ISSN: 2278-0181, Vol. 3 Issue 11, November-2014, (2014)
- [4]. **Spallone, R.,** *3D Digital Modelling as a method for the reconstruction of the historical image of the city: the case of piazza Bodoni in Turin (Italy) at the end of nineteenth century*, XXI International CIPA Symposium, 2007, Athens.
- [5]. **Willis, A., Galor, K.,** *Parsing Architecture within Plan Drawings with Application to Medieval Castles and Fortresses*, The 10th International Symposium on Virtual Reality, Archaeology and Cultural Heritage VAST, (2009)
- [6]. **Willis, A., Galor, K., Sanders, D.,** *Estimating Gothic Façade Architecture from Imagery*, Conference Paper, DOI:10.1109/CVPRW2010.5543519, (2010)